



DESIGNED FOR HIGH VOLUME APPLICATIONS

20 Gallons per Hour – 5 Quart Evaporator Capacity

AUTO-FILL SYSTEM FOR CONTINUOUS PRODUCT SUPPLY!

The **SaniServ** model WB700 Remote Refrigeration Auto-Fill Frozen Beverage Freezer is designed to provide a high volume of frozen beverages through a continuous product source such as; “bag in the box” or pre-mixed product supply systems! The WB700 remote refrigeration system is ideal for lowering costly indoor air conditioning operating costs by providing less heat build up while providing quieter operation! The space saving design of the WB700 is a perfect solution to provide countertops with frozen beverages!

SUPER SPACE SAVING

Small Footprint Design - SaniServ model WB700 offers frozen beverages in the smallest space saving equipment and design available! Owners and Operators can turn even the smallest of countertop space into a high profit center while enjoying lower indoor operating costs and providing the frozen beverages customers want!

EASY CLEANING AND OPERATION

Fewer Parts = Simplified Cleaning – SaniServ equipment is designed and built with the fewer parts to be disassembled, cleaned and sanitized than any other machine in the industry. The state of the art solid-state **AccuFreeze** control insures product consistency, worry-free operation and customer satisfaction.

HIGH RETURN ON INVESTMENT

Increased Profits – SaniServ machines combine affordable efficiency with consistent product quality and fast quiet operation to insure customer satisfaction with high profit frozen beverages.

QUALITY DESIGN

Durability – SaniServ machines are built to achieve long and dependable life through simplicity of design. Every machine is shipped standard with a stainless steel exterior, durable steel interior frame construction, heavy-duty components and consistency systems.

Model WB700

Countertop
**Remote Refrigeration
Frozen Beverage Machine
With AccuFreeze Control**



Made in USA

We reserve the right to change specifications and products design without notice. Such revisions do not entitle the buyer to corresponding changes, improvements, additions or replacements for previously purchased equipment

MODEL WB700

Counter Model Frozen Beverage Freezer w/Remote Condenser & Remote Fill

These units may interface with existing beer and wine transfer systems by the addition of an additional regulator to further reduce the pressure of the normal system.

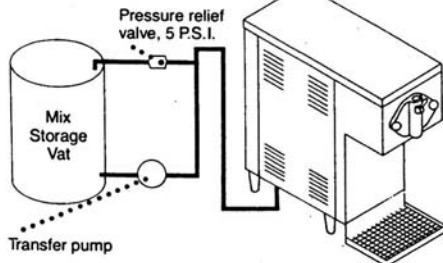

Note: This unit requires remote refrigeration system, not shown.

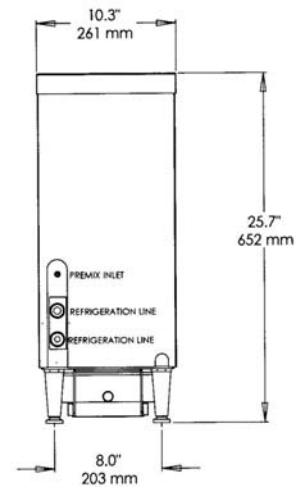
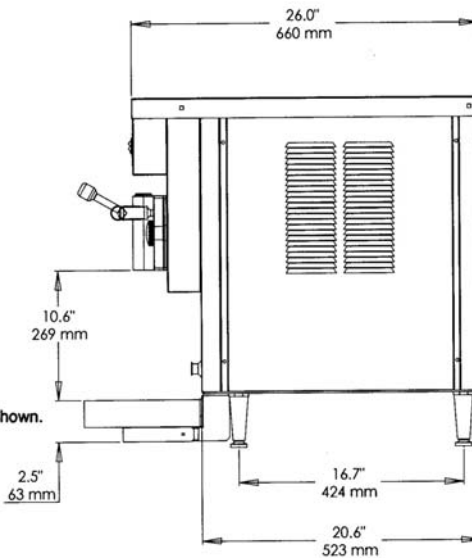

Minimum Wall Clearance
Both Sides and Back -
6 inches (152 mm)

ELECTRICAL				WIDTH	HEIGHT	DEPTH	WEIGHT	VOLUME
VOLTS	Hz	Ph.	Amps	INCHES (MM)	INCHES (MM)	INCHES (MM)	LBS. (Kg)	CU FT. (cu. m.)
115	60	1	15	10.3 (261)	25.7 (652)	26.0 (660)	105 (48)	
Shipping Specifications				22.5 (572)	36.5 (965)	36.5 (927)	135 (61)	18 (.51)

Specifications:

Cooling System:
Remote Required

Dasher Motor:
1/4 HP

Refrigerant Type:
R404A

Listings:
UL, cUL, NSF

Required additional equipment:
Remote Condenser and Compressor

Pre-mixed Product Delivery System

Features:

Evaporator and Mix Reservoir Capacity:
5 Quarts (4.7 liters)

Dasher:
Heavy-Duty Stainless Steel with low friction scraper blades.

Controls:
AccuFreeze solid-state control for accurate product consistency.

Solid State Audio/Visual Mix Out System with Compressor Lockout

Warranty:

Parts 1 year
Compressor Not provided

Options:

Tune Up Kit
Parts Tray
Drink Spinner
Machine Stand
Export Voltage