



## DESIGNED FOR THE HIGHEST VOLUME APPLICATIONS 28 Gallons per Hour – 35 Quart Capacity

### A FROZEN BEVERAGE INDUSTRY LEADER!

The **SaniServ** model 704 Frozen Beverage Freezer is perfect for providing a high volume of frozen drinks for the busiest applications and operating hours! The 704 has the highest production capability in the frozen beverage industry! With its quick product freezing and recovery time, along with heavy-duty design, large capacity freezing barrel and product reservoir, the 704 can provide perfect frozen drinks every time!

### SPACE SAVING

**Small Footprint Design - SaniServ** model 704 provides super high production while saving valuable floor space by utilizing the countertop design. With the 704, there is no need to purchase a floor model type machine to attain high production capacity and capability.

### EASY CLEANING AND OPERATION

**Fewer Parts = Simplified Cleaning – SaniServ** equipment is designed and built with the fewer parts to be disassembled, cleaned and sanitized than any other machine in the industry. The state of the art solid-state **AccuFreeze** control insures product consistency, worry-free operation and customer satisfaction.

### HIGH RETURN ON INVESTMENT

**Increased Profits – SaniServ** machines combine affordable efficiency with consistent product quality and fast quiet operation to insure customer satisfaction with high profit frozen beverages.

### QUALITY DESIGN

**Durability – SaniServ** machines are built to achieve long and dependable life through simplicity of design. Every machine is shipped standard with a stainless steel exterior, durable steel interior frame construction, heavy-duty components and consistency systems.

# Model 704

Counter Model

**Frozen Beverage Machine  
With AccuFreeze Control**



Made in USA

We reserve the right to change specifications and products design without notice. Such revisions do not entitle the buyer to corresponding changes, improvements, additions or replacements for previously purchased equipment



# MODEL 704

## Counter Model Frozen Beverage/Cocktail Freezer

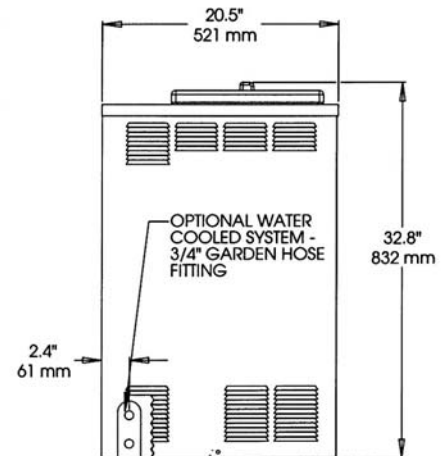
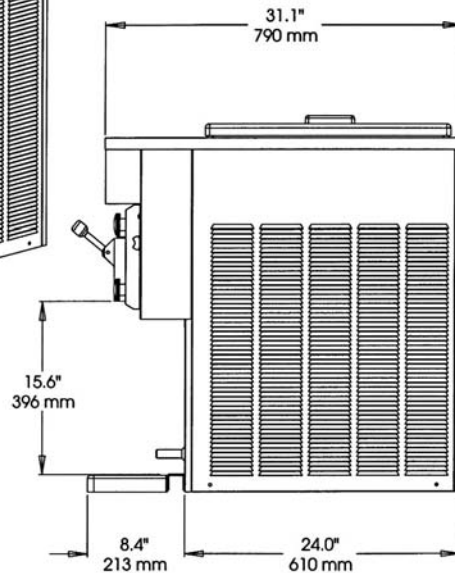
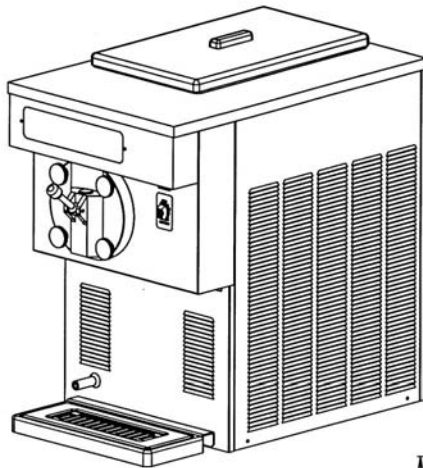

Minimum Wall Clearance  
Both Sides and Back -  
6 inches (152 mm)

ELECTRICAL				WIDTH	HEIGHT	DEPTH	WEIGHT	VOLUME
VOLTS	Hz	Ph.	Amps	INCHES (MM)	INCHES (MM)	INCHES (MM)	LBS. (Kg)	CU FT. (cu. m.)
208-230	60	1	25	20.5 (521)	32.8 (832)	31.1 (790)	310 (141)	
208-230	60	3	20					
Shipping Specifications				31.5 (800)	40.5 (1029)	40.5 (1029)	350 (159)	29.9 (.84)

### Specifications:

#### Cooling System:

Air or Water

#### Dasher and Compressor Motors:

1/2 HP Dasher  
2 HP Compressor

#### Refrigerant Type:

R404A

#### Listings:

UL, cUL, NSF

### Features:

#### Evaporator and Mix Reservoir

**Capacity:**  
35 Quarts (33 liters)

#### Dasher:

Heavy-Duty Stainless Steel with low friction scraper blades.

#### Controls:

**AccuFreeze** solid-state control for accurate product consistency.

#### Solid State Audio/Visual Mix Out System with Compressor Lockout

Includes Counter Top Mounting Pad

### Warranty:

Parts 1 year  
Compressor 5 years  
Evaporator 5 years

### Options:

Tune Up Kit      Parts Tray  
Auto-fill Lid      Drink Spinner  
Machine Stand      Counter Legs  
Water Cooled - 3/4" Garden Hose Fitting  
Export Voltage  
Remote Condenser\*

\* Requires a remote condensing unit (condenser & compressor) connected by two refrigeration lines.