



## DESIGNED FOR HIGH VOLUME APPLICATIONS

### 16 Gallons per Hour – 25 Quart Capacity

#### HIGH FROZEN PRODUCT VISIBILITY MEANS HIGH PROFITS!

The **SaniServ** model 108R Frozen Beverage Freezer provides owners and operators everything they are asking for: *Frozen beverage visibility merchandising* in a consistent and reliable machine with *remote refrigeration* and *remote auto fill!* The unit's extra large 8" faceplate design allows customers to view colorful frozen beverages being offered without the condensation and unreliable operation of traditional "bubble top" machines! The high frozen product visibility, along with increased production and reliability, results in increased sales and high profits! The 108R's remote refrigeration system is ideal for lowering costly indoor air conditioning operating costs by providing less heat build up while providing quieter operation!

#### SPACE SAVING

**Small Footprint Design - SaniServ** model 108R offers frozen product visibility in reliable space saving equipment and design! Owners and Operators can turn the countertop into a highly colorful profit center by providing the frozen beverages customers enjoy!

#### EASY CLEANING AND OPERATION

**Fewer Parts = Simplified Cleaning – SaniServ** equipment is designed and built with the fewer parts to be disassembled, cleaned and sanitized than any other machine in the industry.

#### HIGH RETURN ON INVESTMENT

**Increased Profits – SaniServ** machines combine affordable efficiency with consistent product quality and fast quiet operation to insure customer satisfaction with high profit frozen beverages.

#### QUALITY DESIGN

**Durability – SaniServ** machines are built to achieve long and dependable life through simplicity of design. Every machine is shipped standard with a stainless steel exterior, durable steel interior frame construction, heavy-duty components and consistency systems.

# Model 108R

Countertop  
**Frozen Beverage Machine**  
*Remote Fill & Remote Condenser*



Made in USA

We reserve the right to change specifications and products design without notice. Such revisions do not entitle the buyer to corresponding changes, improvements, additions or replacements for previously purchased equipment



# MODEL 108R

## Counter Frozen Beverage Freezer w/Remote Condenser

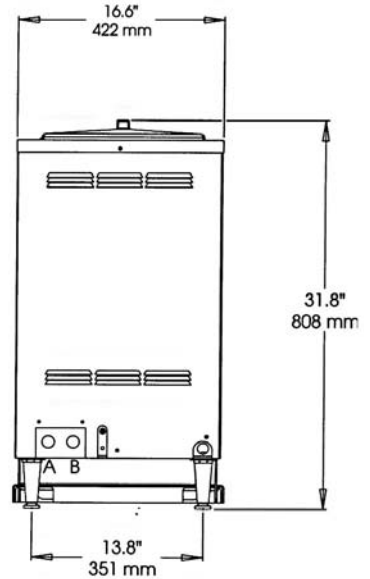
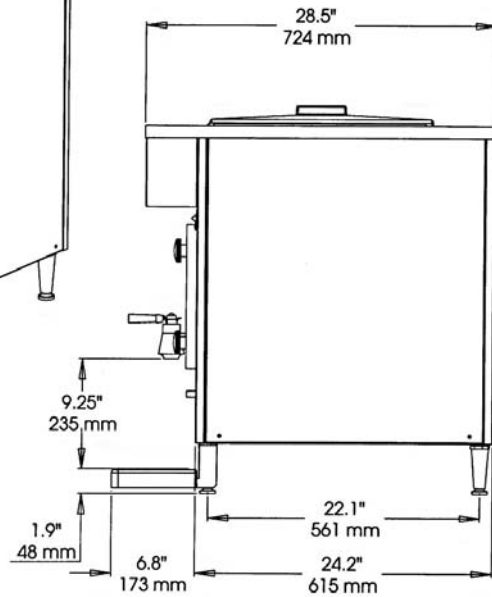
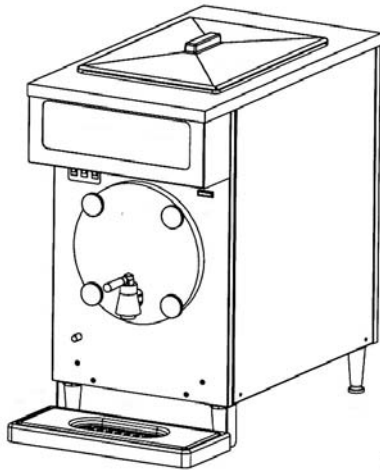

Minimum Wall Clearance  
Both Sides and Back -  
6 inches (152 mm)

A 5/8" SUCTION LINE QUICK DISCONNECT  
B 3/8" LIQUID LINE QUICK DISCONNECT

ELECTRICAL				WIDTH	HEIGHT	DEPTH	WEIGHT	VOLUME
VOLTS	Hz	Ph.	Amps	INCHES (MM)	INCHES (MM)	INCHES (MM)	LBS. (Kg)	CU FT. (cu. m.)
115	60	1	15	16.6 (422)	31.8 (808)	28.5 (724)	150 (69)	
Shipping Specifications				22.5 (572)	36.5 (965)	36.5 (927)	185 (85)	18 (.51)

### Specifications:

**Cooling System:**  
Remote Required

**Dasher Motor:**  
1/2 HP

**Refrigerant Type:**  
R404A

**Listings:**  
NSF

### Features:

**Evaporator and Mix Reservoir**  
**Capacity:**  
25 Quarts (23.6 liters)

**Dasher:**  
Heavy-Duty Stainless Steel with low friction scraper blades.

**Controls:**  
Automatic consistency controls for improved product consistency.

**Solid-state Automatic Visual Mix Out Alert System**

### Warranty:

Parts 1 year  
Evaporator 5 years

### Options:

Tune Up Kit  
Parts Tray  
Drink Spinner  
Machine Stand  
Export Voltage  
Wash Out Kit – 3/8" Flare Fitting  
Remote Condenser\*

\* Requires a remote condensing unit (condenser & compressor) connected by two refrigeration lines.